

XLR™ Processors

RMI's XLR Processor™ solutions are multi-core and multi-threaded devices that provide a rich set of features and performance to address the wide variety of integrated next generation applications, including integrated security (firewall, VPN, anti-virus, intrusion detection and prevention), web services, virtualized storage, load balancing, server offload and intelligent routing and switching systems.

- The XLR500 series incorporates four separate Gigabit Ethernet interfaces. The high-performance product offerings in this family include the XLR532 and XLR516, with the XLR508 mid-performance product offering completing the family.
- The XLR700 series boosts the capability of the XLR500 series by incorporating dual 10 Gigabit Ethernet or SPI 4.2 interfaces. The high-performance product offerings in this family include the XLR732 and XLR716.
- The XLR700 and XLR500 series processors are software and hardware compatible.

Each XLR Processor is available in a variety of power options, including standard, low and ultra low power. XLR Processors are also available in industrial and commercial temperature versions.

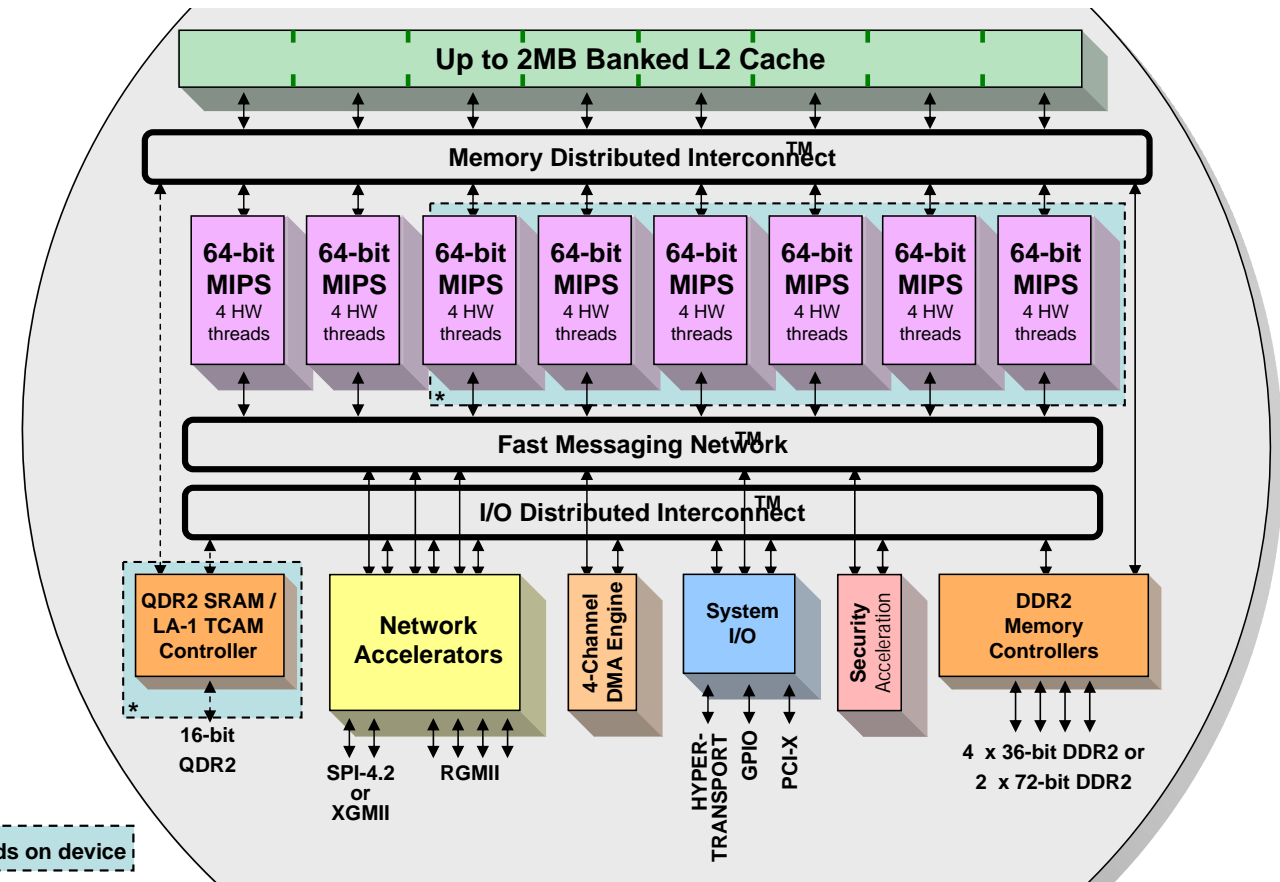

XLR™ Processors																	
Device Number	Frequency	Cores/Threads	L2 Cache	Security	Security Performance	DRAM Memory	Memory Channels	Memory Speed	1 GE Ports	10 GE Ports	QDR/LA-1	HT	I/O	Package	Core Power Options ¹		
															Standard Power	Low Power	Ultra Low Power
XLR 732	800MHz - 1.2GHz	8C/32T	2MB	AES, TDES, ARC4, RSA, SHA, MD5, Katsumi	10Gbps	DDR2	4x36b, 2x72b	533 MHz	4xRGMII	2x10GE/SPI-4.2	Yes	Yes	PCI-X, 64b/133MHz	1605 BGA	49	39	29
XLR 716	800MHz - 1.2GHz	4C/16T	1MB	AES, TDES, ARC4, RSA, SHA, MD5, Katsumi	5Gbps	DDR2	4x36b, 2x72b	533 MHz	4xRGMII	2x10GE/SPI-4.2	Yes	Yes	PCI-X, 64b/133MHz	1605 BGA	32	27	20
XLR 532	800MHz - 1.2GHz	8C/32T	2MB	AES, TDES, ARC4, RSA, SHA, MD5, Katsumi	10Gbps	DDR2	4x36b, 2x72b	533 MHz	4xRGMII	--	No	Yes	PCI-X, 64b/133MHz	1605 BGA	45	37	27
XLR 516	800MHz - 1.2GHz	4C/16T	1MB	AES, TDES, ARC4, RSA, SHA, MD5, Katsumi	5Gbps	DDR2	4x36b, 2x72b	533 MHz	4xRGMII	--	No	Yes	PCI-X, 64b/133MHz	1605 BGA	28	24	18
XLR 508	800MHz - 1.2GHz	2C/8T	512KB	AES, TDES, ARC4, RSA, SHA, MD5, Katsumi	2.5Gbps	DDR2	4x36b, 2x72b	533 MHz	4xRGMII	--	No	Yes	PCI-X, 64b/133MHz	1605 BGA	23	17	13

1. Wattage values rounded to nearest whole number.

XLS™ Processors

RMI's XLS Processor™ solutions are cost-effective multi-core and multi-threaded devices that provide a rich set of features and performance for SMB and client oriented solutions. These solutions include integrated security (firewall, VPN, anti-virus, intrusion detection and prevention), access points, router and switch products.

- The XLS600 series is distinguished by integral quad memory controllers and eight Gigabit Ethernet interfaces. The XLS616 also includes 10 Gb XAUI ports.
- The XLS400 series scales from medium-to-high performance and integrates eight Gigabit Ethernet interfaces and dual memory controllers. The XLS416 also includes 10 Gb XAUI ports.
- The XLS200 series, with four Gigabit Ethernet ports and a DDR2 memory controller, is a low-cost high-performance solution for control plane applications. Quad PCIe controllers allow switchless interconnect to other devices in the system.
- The XLS100 series, with three Gigabit Ethernet ports and a DDR2 memory controller, is a low-cost mid-performance solution for control plane applications. Dual PCIe controllers allow switchless interconnect to other devices in the system.

Each XLS Processor is software- and hardware-compatible with other devices within its series. All XLS series are software compatible with other series. The XLS400, XLS200, and XLS100 series processors are pin-compatible.

XLS Processors support standard industrial operating temperatures.

* = depends on device

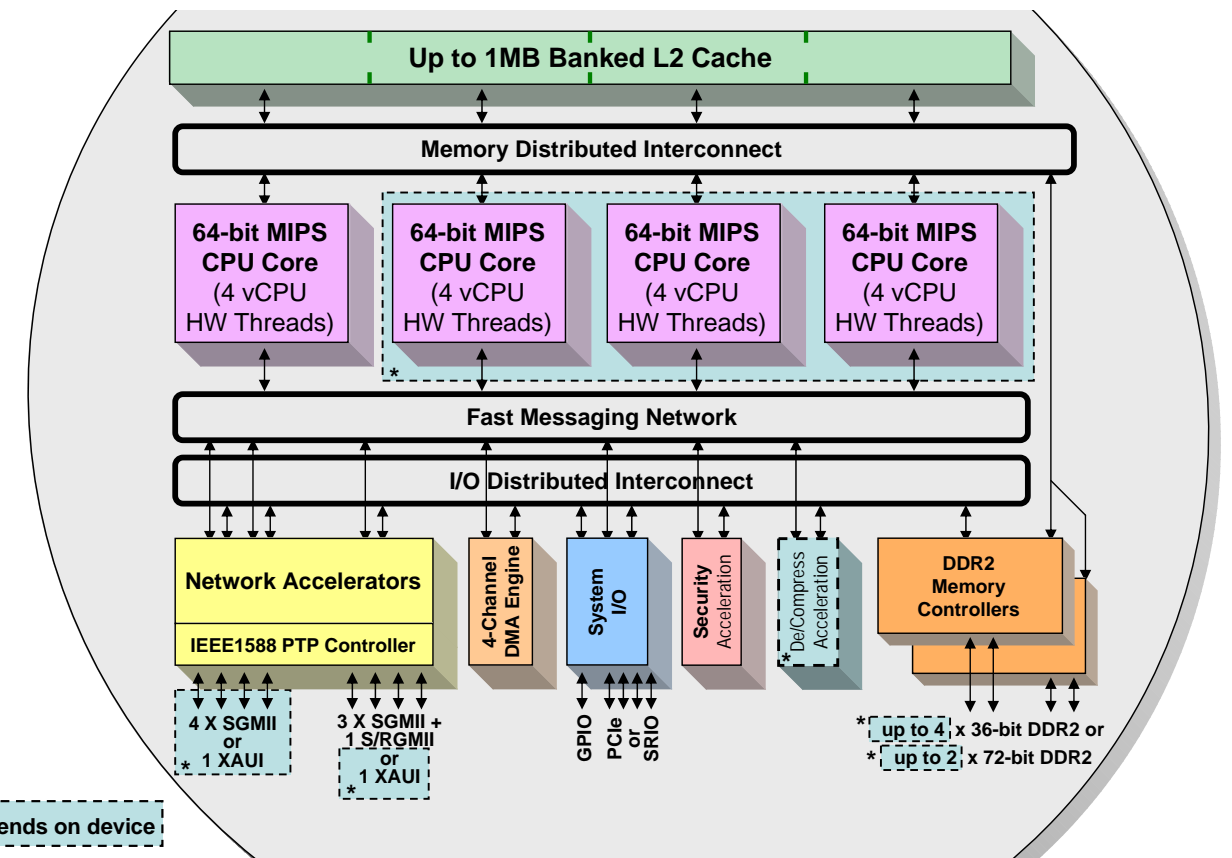

XLS™ Processors

Device Number	Frequency	Cores / Threads	L1-I/L1-D Cache	L2 Cache	Security	Security Performance	Compress. Accel.	DRAM Memory	Memory Channels	Memory Speed	Ethernet Ports	IEEE 1588 PTP	USB Ports	PCI-E ctrls x lanes	SRIO ctrls x lanes	Package	Power (Watts)
XLS 616	800 MHz - 1.2 GHz	4C/16T	32KB/32KB	1 MB	DES, 3DES, AES, AES-GCM, SHA, MD5, ECC, RSA, Katsumi	2.5 Gbps	2.5 Gbps	DDR2	4x36b, 2x72b	533 MHz	8x 1GE / 2x 10Gb XAUI	v2	2	1 x4 or 4 x1	1 x4 or 4 x1	957 BGA	< 29
XLS 608	800 MHz - 1.2 GHz	2C/8T	32KB/32KB	1 MB	DES, 3DES, AES, AES-GCM, SHA, MD5, ECC, RSA, Katsumi	2.5 Gbps	2.5 Gbps	DDR2	4x36b, 2x72b	533 MHz	8x 1GE / 2x 10Gb XAUI	v2	2	1 x4 or 4 x1	1 x4 or 4 x1	957 BGA	< 20
XLS 416	800 MHz - 1.2 GHz	4C/16T	32KB/32KB	1 MB	DES, 3DES, AES, AES-GCM, SHA, MD5, ECC, RSA, Katsumi	2.5 Gbps	2.5 Gbps	DDR2	2x36b, 1x72b	533 MHz	8x 1GE / 2x 10Gb XAUI	v2	2	1 x4 or 4 x1	1 x4 or 4 x1	845 BGA	< 28
XLS 408B	600 MHz - 1.2 GHz	2C/8T	32KB/32KB	1 MB	DES, 3DES, AES, AES-GCM, SHA, MD5, ECC, RSA, Katsumi	2.5 Gbps	2.5 Gbps	DDR2	2x36b, 1x72b	533 MHz	8x 1GE / 1x 10Gb XAUI	v2	2	1 x4 or 4 x1	1 x4 or 4 x1	845 BGA	< 20
XLS 408A	600 MHz - 1.2 GHz	2C/8T	32KB/32KB	1 MB	DES, 3DES, AES, AES-GCM, SHA, MD5, ECC, RSA, Katsumi	2.5 Gbps	--	DDR2	2x36b, 1x72b	533 MHz	8x 1GE	--	2	1 x4 or 2 x1	--	845 BGA	< 20
XLS 404B	600 MHz - 1.2 GHz	1C/4T	32KB/32KB	512 KB	DES, 3DES, AES, AES-GCM, SHA, MD5, ECC, RSA, Katsumi	1.25 Gbps	1.25 Gbps	DDR2	2x36b, 1x72b	533 MHz	8x 1GE	v2	2	1 x4 or 4 x1	1 x4 or 4 x1	845 BGA	< 17
XLS 404A	600 MHz - 1.2 GHz	1C/4T	32KB/32KB	512 KB	DES, 3DES, AES, AES-GCM, SHA, MD5, ECC, RSA, Katsumi	1.25 Gbps	--	DDR2	2x36b, 1x72b	533 MHz	8x 1GE	--	2	1 x4 or 2 x1	--	845 BGA	< 17
XLS 208	600 MHz - 1.0 GHz	2C/8T	32KB/32KB	512 KB	DES, 3DES, AES, AES-GCM, SHA, MD5, ECC, RSA, Katsumi	1.0 Gbps	--	DDR2	1x36b, 1x72b	533 MHz	4x1GE	--	2	4 x 1	--	845 BGA	< 12
XLS 204	600 MHz - 1.0 GHz	1C/4T	32KB/32KB	256 KB	DES, 3DES, AES, AES-GCM, SHA, MD5, ECC, RSA, Katsumi	1.0 Gbps	--	DDR2	1x36b, 1x72b	533 MHz	4x1GE	--	2	4 x 1	--	845 BGA	< 8
XLS108	500 MHz - 750 MHz	2C/8T	32KB/32KB	512 KB	DES, 3DES, AES, AES-GCM, SHA, MD5, ECC, RSA, Katsumi	0.75 Gbps	--	DDR2	1x36b	533 MHz	3x1GE	--	1	2 x 1	--	845 BGA	< 8
XLS104	500 MHz - 750 MHz	1C/4T	32KB/32KB	256 KB	DES, 3DES, AES, AES-GCM, SHA, MD5, ECC, RSA, Katsumi	0.75 Gbps	--	DDR2	1x36b	533 MHz	3x1GE	--	1	2 x 1	--	845 BGA	< 6

About RMI Corporation

RMI Corporation® (RMI) is a fabless semiconductor company providing highly-integrated feature-rich products ranging from power-optimized Super Soc™ solutions to High-Performance Processors for the Digital Consumer, Wireless, Networking and Security markets. RMI offers the most advanced and most complete MIPS®-Compatible Processing solutions with both 32/64-bit architectures supporting frequencies from 300 MHz to 1.2 GHz. The company is headquartered in Cupertino, CA with offices in Texas, United Kingdom, India, Korea, Japan, Taiwan and China. More information about RMI can be found on the company's website at www.RMICorp.com

Copyright© 2008 RMI Corporation. All rights reserved. The information in this document is proprietary and confidential to RMI. RMI reserves the right to revise this document and to make changes to its products from time to time without obligation to provide notification of such revision or change. RMI provides this document without warranty, term or condition of any kind, either express or implied.

RMI, the stylized RMI logo, XLS, XLS Processor, XLS-Based, XLR, XLR Processor, XLR-Based, Thread Processor, Autonomous Security Acceleration Engine, Autonomous Network Acceleration Engine, Autonomous Acceleration Engine, Fast Messaging Network, Memory Distributed Interconnect, I/O Distributed Interconnect, Packet Distribution Engine, vCPU, SuperSOC, Scalable Processor Solutions and Communication Processor Solutions are trademarks or registered trademarks of RMI Corporation in the United States and other countries. A list of other trademarks and registered RMI trademarks can be found on the Company's corporate website located at www.rmicorp.com. Other company, product or service names mentioned in this document may be trademarks or service marks of their respective owners.